

APPLICATION NOTE 10

Lower Operating Frequency Improves ICL7660 Voltage-Conversion Efficiency

Abstract: This design note shows how to improve the efficiency of a voltage converter by lowering the oscillator frequency. Adding an oscillator capacitor to a 20mA voltage converter lowers the oscillator frequency, improving voltage conversion efficiency for lower values of IO. The ICL7660 charge pump is featured.

You can improve the efficiency of an ICL7660 voltage-conversion circuit by lowering the oscillator frequency and increasing the external capacitor values. Though useful for modest levels of IO, this technique is not clearly described in the data sheet. (The CMOS ICL7660, available in an 8-lead DIP or TO-99 can, is a charge-pump device that converts inputs in the range 1.5V to 10V to corresponding negative outputs in the range -1.5V to -10V.)

The ICL7660's conversion efficiency depends on its quiescent supply current, which in turn depends on the internal charge pump's drive frequency. The chip's oscillator and divide-by-two circuit normally set the frequency between 4kHz and 5kHz. Using the recommended 10µF values for the flying capacitor and the reservoir capacitor, this configuration consumes about 10µA of quiescent supply current while providing a conservative 10mA of output current.

Increasing the frequency by overriding the oscillator with an externally applied signal causes a proportional increase in the quiescent current. Or, connecting an external oscillator capacitor to pin 7 (Figure 1) slows the oscillator, causing supply current to approach a minimum value of about 10µA at 10Hz (Figure 2).

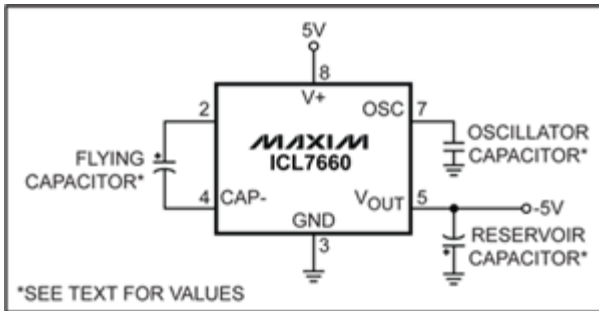

Figure 1. Adding an oscillator capacitor to the typical ICL7660 application lowers the oscillator frequency, which for lower values of IO results in more efficient voltage conversion.

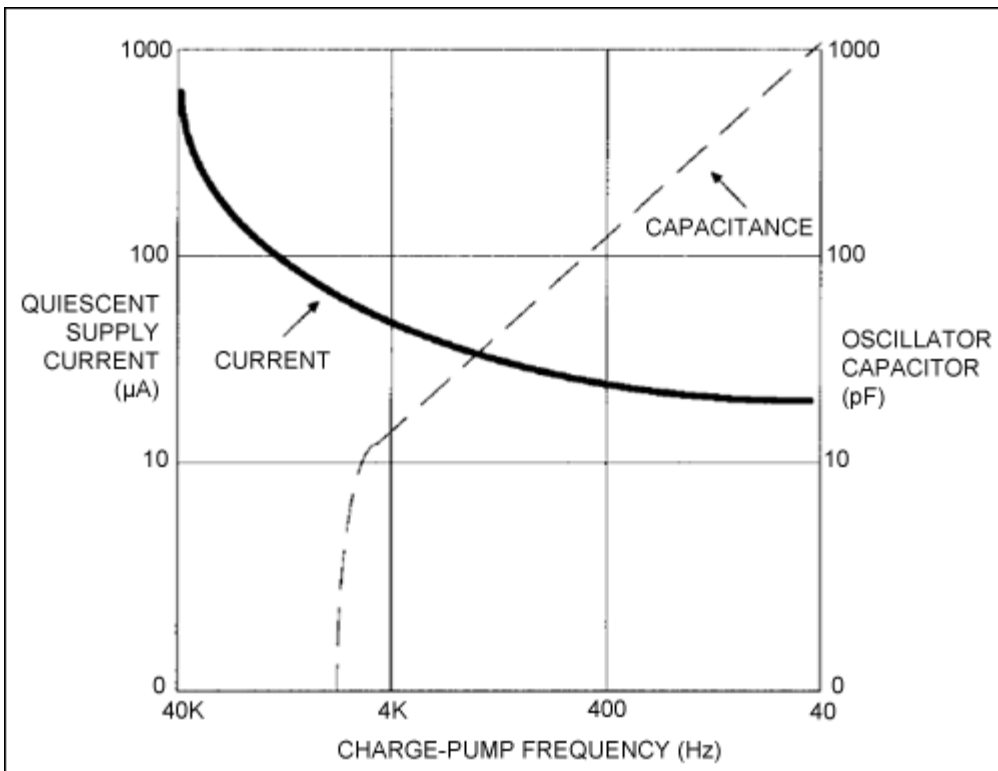

Figure 2. The "capacitance" curve relates the value of oscillator capacitor chosen in Figure 1 to the resulting charge-pump frequency. The "current" curve relates charge-pump frequency to the resulting quiescent supply current (left vertical axis).

Slowing the oscillator improves efficiency, but to avoid a corresponding increase in ripple voltage you must also make inversely proportional changes in the flying capacitor and the reservoir capacitor. For example, setting the oscillator to 100Hz by connecting 100pF to pin 7 requires that you increase the flying and reservoir capacitors to 100µF. Such an arrangement still provides 20mA of output current but consumes only one fifth the quiescent current (15µA).

Note that you can reduce the capacitor values if lower IO is allowed. Setting the oscillator to 40Hz, for example, (by connecting 1000pF to pin 7) provides the highest efficiency possible. Leaving the flying and reservoir capacitors at 100µF gives a maximum IO of 2mA, a no-load quiescent current of 10µA, and a power-conversion efficiency of 98%.

Related Parts

[ICL7660 Switched-Capacitor Voltage Converters -- Free Samples](#)

Automatic Updates

Would you like to be automatically notified when new application notes are published in your areas of interest? [Sign up for EE-Mail™](#).

Application note 10: www.maxim-ic.com/an10

More information

For technical support: www.maxim-ic.com/support

For samples: www.maxim-ic.com/samples

Other questions and comments: www.maxim-ic.com/contact

AN10, AN 10, APP10, Appnote10, Appnote 10

Copyright © by Maxim Integrated Products

Additional legal notices: www.maxim-ic.com/legal