

WORLD'S SMALLEST 32-TAP, LINEAR, NONVOLATILE I²C DIGITAL POTS

Tiny 3mm x 3mm SOT23 or TDFN Package!

The MAX5432–MAX5435 family of 32-tap digital potentiometers are available in resistor-divider or variable resistor configurations. On-chip EEPROM simulates mechanical potentiometer operation by storing the wiper position for power-up.

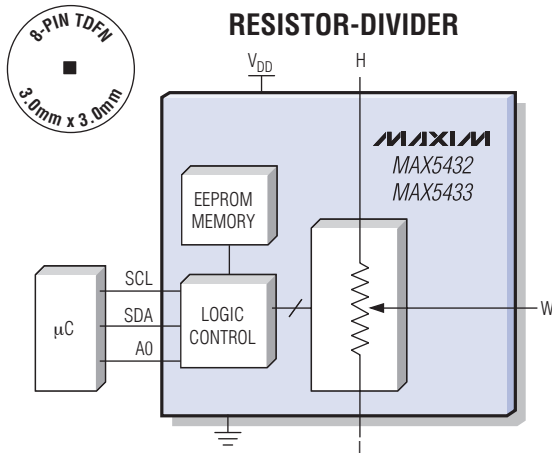

**Ultra-Low 35ppm/°C
End-to-End and 5ppm/°C
Ratiometric Temperature Drift!**

- ◆ On-Chip EEPROM Stores Wiper Position For Power-Up
- ◆ Simple 2-Wire, I²C[‡]-Compatible Interface
- ◆ Single 2.7V to 5.25V Supply Voltage
- ◆ Consumes Less than 1µA Supply Current
- ◆ Four Address Options per Device Allow Multiple Devices on the Same Bus

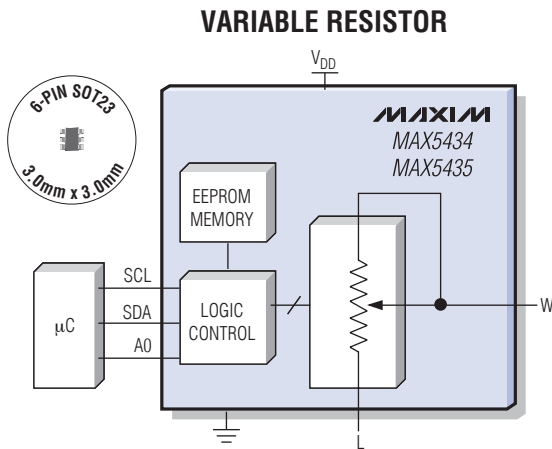

Choose from Resistor-Divider or Variable Resistor Configurations

| Part | Resistor Steps | Resistor Configuration | End-to-End Resistance (kΩ) | Package | Price [†] (\$) |
|---------|----------------|------------------------|----------------------------|---------|-------------------------|
| MAX5432 | 32 | Resistor-divider | 50 | 8-TDFN | 0.63 |
| MAX5433 | 32 | Resistor-divider | 100 | 8-TDFN | 0.63 |
| MAX5434 | 32 | Variable resistor | 50 | 6-SOT23 | 0.63 |
| MAX5435 | 32 | Variable resistor | 100 | 6-SOT23 | 0.63 |

[‡]Purchase of I²C components from Maxim Integrated Products, Inc., or one of its sublicensed Associated Companies, conveys a license under the Philips I²C Patent Rights to use these components in an I²C system, provided that the system conforms to the I²C Standard Specification defined by Philips.

[†]1000-up recommended resale. Price provided is for design guidance and is FOB USA. International prices will differ due to local duties, taxes, and exchange rates. Not all packages are offered in 1k increments, and some may require minimum order quantities.



www.maxim-ic.com

FREE Digital Potentiometers Design Guide—Sent Within 24 Hours!

CALL TOLL FREE 1-800-998-8800 (6:00 a.m.–6:00 p.m. PT)

For a Design Guide or Free Sample



Distributed by Maxim/Dallas Direct!, Arrow, Avnet Electronics Marketing, Digi-Key, and Newark.

The Maxim logo is a registered trademark of Maxim Integrated Products, Inc. The Dallas Semiconductor logo is a registered trademark of Dallas Semiconductor Corp.

© 2004 Maxim Integrated Products, Inc. All rights reserved.