

DSP-BASED 16-BIT SIGNAL CONDITIONER ALLOWS CUSTOMIZED SENSOR COMPENSATION

Dual-Channel, Multi-Order Linearity and Temperature Correction

✓ CHECK OUT
TECH TIPS AT
www.maxim-ic.com

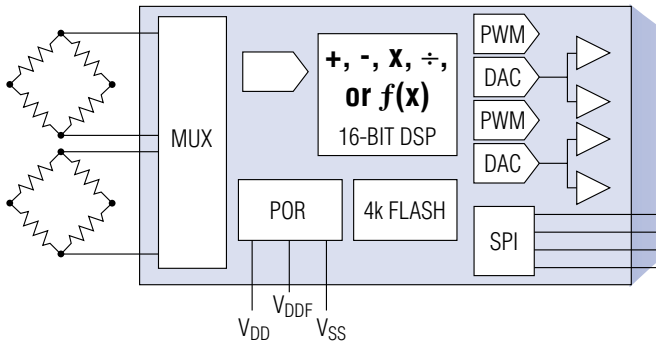

The MAX1463 can be user-configured to provide outputs that represent:

- ◆ Separate, Independent Signals
- ◆ The Sum of Inputs
- ◆ The Difference of Inputs
- Or...
- ◆ Any Function Programmed by the User into the On-Chip DSP

- ◆ Accepts Sensor Output Sensitivities from 1mV/V to 1V/V
- ◆ Two Differential Input or Four Single-Ended Sensor Input Channels
- ◆ Integrated Temperature Sensor
- ◆ Two Analog or Digital Output Channels; Outputs Include: 4–20mA, 0.5V to 4.5V, and PWM
- ◆ User-Programmable Signal Correction, Sensor Gain and Offset, Sampling Rate and Resolution
- ◆ Supports Current or Voltage Bridge Excitation

Choose from a Wide Range of Integrated Signal Conditioning ICs

PART	OUTPUT	COMPENSATION METHOD	SUPPLY VOLTAGE (V)	TEMPERATURE SENSOR	EEPROM
MAX1463	Dual-channel digital and analog outputs, 0.5V to 4.5V, 4–20mA, PWM	RISC processor, 16-bit ADC + DSP	5 (400µA)	Internal	Internal
MAX1452/ MAX1455	4–20mA, 0.5V to 4.5V, 0 to 5V Rail-to-Rail®, 2.5 ±2.5V	16-bit DACs, select from 2pt to 176pt temperature compensation and two adjustable clipping limits (MAX1455)	5	Internal	Internal
MAX1457	0.5V to 4.5V, 0 to 5V, 4–20mA	16-bit DACs, selectable from 1pt to 120pt temperature compensation and 1pt linearity correction	5	—	External
MAX1462	Digital (parallel) and Analog, 0 to 2.4VDC, 4–20mA	RISC processor, 16-bit ADC + DSP	2.4 (310µA)	Internal	Internal

Rail-to-Rail is a registered trademark of Nippon Motorola, Ltd.



FREE Temp Sensors Design Guide—Sent Within 24 Hours!

CALL TOLL-FREE 1-800-998-8800 (6:00 a.m. – 6:00 p.m. PST)

For a Design Guide or Free Sample

MAXIM

www.maxim-ic.com

2002 EDITION!
FREE FULL-LINE DATA CATALOG
ON CD-ROM



MAXIM/DALLAS
DIRECT!
DISTRIBUTION
1-888-MAXIM-IC

ARROW
ARROW ELECTRONICS, INC.
1-800-777-2776

AVNET
CILICON
1-800-332-8638

Distributed by Maxim/Dallas Direct!, Arrow, Avnet Electronics Marketing, Digi-Key, and Newark.

MAXIM is a registered trademark of Maxim Integrated Products, Inc. © 2003 Maxim Integrated Products.