

DS12885/87 NOW AVAILABLE IN 3.3V

Trickle-Charge Output Enables Backup with Super Cap

Convert systems using the industry-standard DS12885 SO mux-bus clock to 3.3V without changing the layout or firmware. A previously unused pin provides an always-enabled trickle charger and serves as a backup input supply in the absence of V_{CC}. The DS12CR887 includes a battery and crystal, and is packaged in a 24-pin encapsulated module, making it a drop-in replacement for the original DS12887. The DS12CR887 is also offered in a new 3.3V version. The battery embedded in the module provides ten years of battery-backup time, so the trickle charger is disabled to ensure complete compatibility with existing DS12887 layouts.

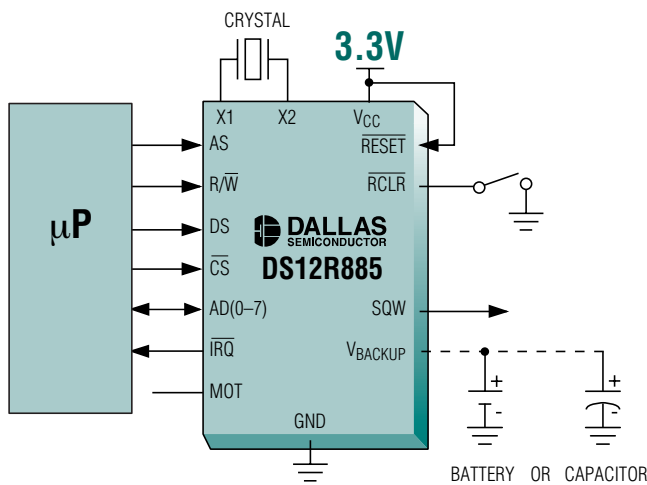

- ◆ Pin/Function Compatible with Original DS12885/87
- ◆ +5V or +3.3V
- ◆ Trickle-Charge Output
- ◆ Available in SO or DIP Module
- ◆ -40°C to +85°C Temperature Range

Part	Trickle Charge	Temp Range (°C)	Voltage (V)	Pin-Package	Price† (\$)
DS12R885-33	Yes	-40 to +85	+3.3	24-SO	2.06
DS12R885-5	Yes	-40 to +85	+5	24-SO	2.06
DS12CR887-33	No	0 to +70	+3.3	24-DIP Module	3.08
DS12CR887-5	No	0 to +70	+5	24-DIP Module	3.08

†1000-up recommended resale. Prices provided are for design guidance and are FOB USA. International prices will differ due to local duties, taxes, and exchange rates. Not all packages are offered in 1k increments, and some may require minimum order quantities.



www.maxim-ic.com

FREE Real-Time Clocks Design Guide—Sent Within 24 Hours!

CALL TOLL FREE 1-800-998-8800 (7:00 a.m.–5:00 p.m. PT)

For a Design Guide or Free Sample



Distributed by Maxim/Dallas Direct!, Arrow, Avnet Electronics Marketing, Digi-Key, and Newark.

The Maxim logo is a registered trademark of Maxim Integrated Products, Inc. The Dallas Semiconductor logo is a registered trademark of Dallas Semiconductor Corp.
© 2006 Maxim Integrated Products, Inc. All rights reserved.